



Rated per UL555S, UL File R6189

# Installation Instructions for 5100 Series Leakage Rated Dampers For Use in Horizontal & Vertical Ducts

Maximum Single Section Size: 36" x 48"

Maximum Multiple Section Assembly: 144" x 96" or 288" x 48"

Class I, II or III (5150-1, 5150-2, 5150-3)

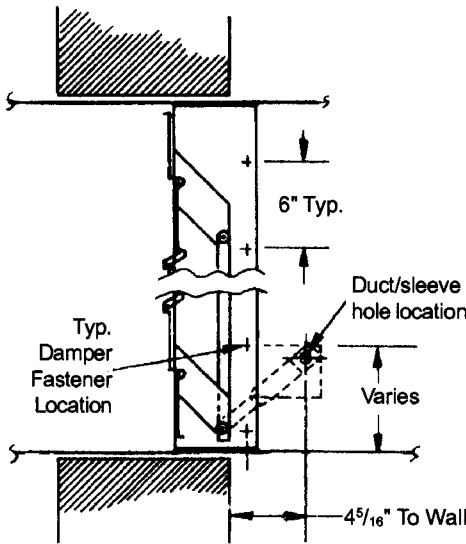

**INSTALLATION 'A'**  
Damper in Duct-Sleeve

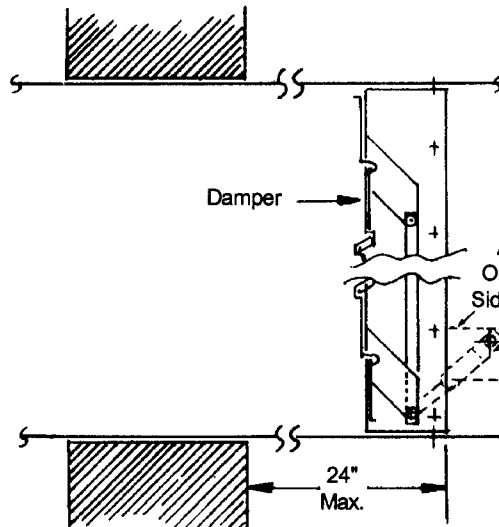

**INSTALLATION 'B'**  
See Special Installation Instructions  
Note 1

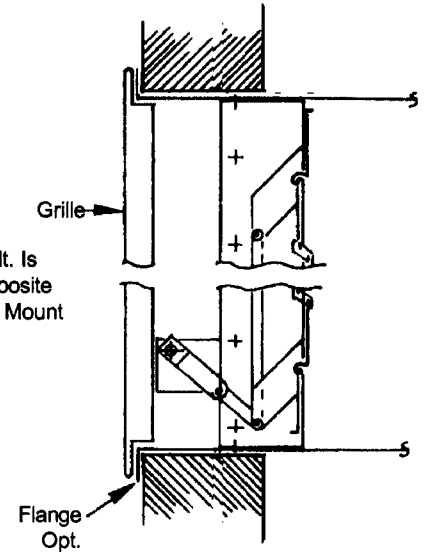

**INSTALLATION 'C'**  
Grille-Damper in Terminal Duct  
For Internal/Motor Operated Units  
(Without Extended Operator Shaft)

Both Vertical and Horizontal Damper  
Installations are Typified by These  
Drawings

### IMPORTANT

For proper blade operation, the mounting fasteners in the frame must not be located in the blade rotating area.

### Installation Notes:

- Leakage rated dampers shall be installed vertically or horizontally in accordance with NFPA 90A at or adjacent to the point where ducts pass through required smoke barriers, but in no case shall the damper be installed more than 24" from barrier or past first duct inlet or outlet.
- Sealant must be used to meet UL555S requirements to create an air tight seal between the damper and the duct/sleeve and also the joint between sections in multiple section assemblies. Sealant shall be applied in a minimum 1/8" bead on the jackshaft side of the damper. After application, press surface of sealant to dispel any trapped air. Any of the following rated sealants are acceptable for use:
  - Carborundum Fiberfrax 'LDS' Moldable
  - Dow Corning Silicone #999
  - Dow Corning Silicone #732 RTV
  - GE RTV Silicone Rubber
- Mounting of Duct/Sleeve into wall should be done per standard HVAC practice.

REPRESENTED BY

MANUFACTURED BY  
PERFECT AIR CONTROL, INC.  
1310 N. HERCULES AVE. CLEARWATER, FL 33765  
CUSTOMER SERVICE (800) 437-6653 \* ORDER ENTRY FAX (727) 431-6074  
www.prefco-hvac.com