

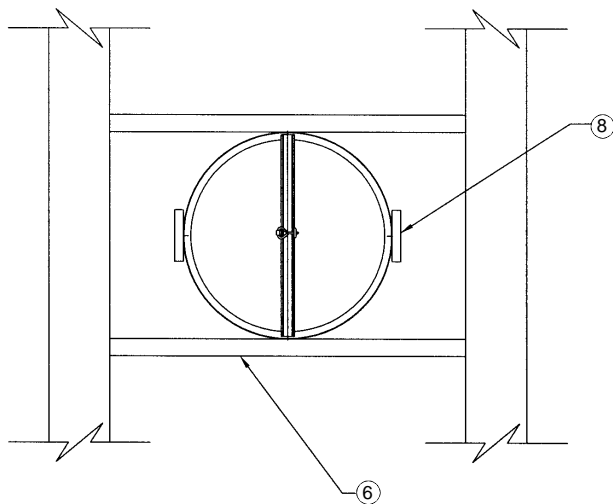

Supplemental Installation Instructions For Models 5600 & 5610 Ceiling Radiation Dampers For Use In Wood And Gypsum Construction Partitions

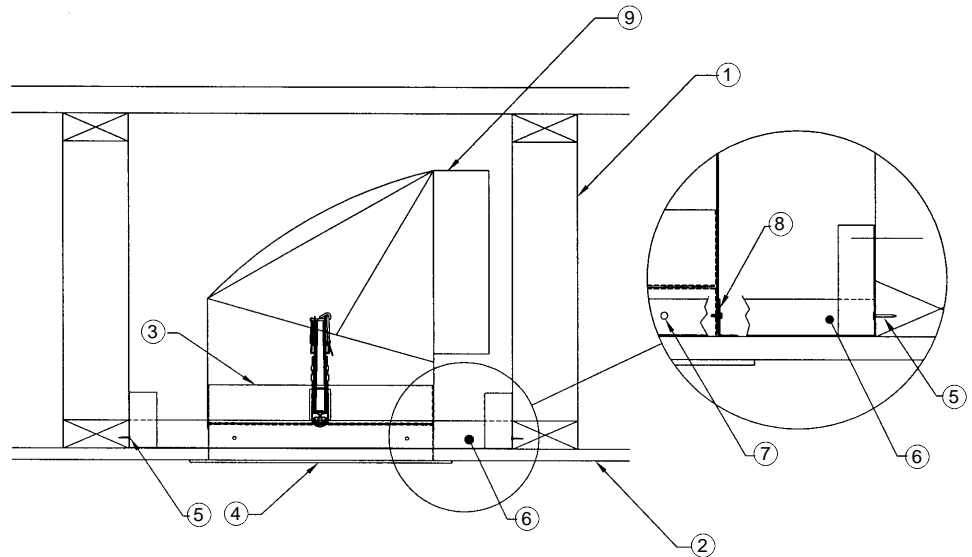

1 Hour rated for use in UL Floor/
Ceiling design numbers: L-521, L-528
and L-546 and UL Roof/Ceiling de-
sign number P-522.



Item Description

1. Floor or Ceiling Trusses
2. Ceiling Gypsum Board
3. Model 5600 Ceiling Radiation Damper (UL555C)
4. Grille, Diffuser or Duct Drop
5. 6d Nail or #8 Screw (8)
6. 1" x 1½" 20 Ga. Galv. Mounting Angle (2)
7. #8 Sheet Metal Screw (4) 5600-5610
8. 1" x 1½" x 3" 20 Ga. Galv. Mounting Angle (2)
9. Transition Boot

NOTES:

1. Measure spacing between framing members and cut the mounting angles (two required) to that length plus 6". Cut the 1" side of each mounting angle approximately 3 inches from each end of the mounting angle and bend angle up 90° at both ends as shown in detailed view above. Attach angles to wood frame with a minimum of two each #6 penny nails or #8 screws.
2. Attach the ceiling damper (or metal surrounds such as sleeve, transition box or boot) to the mounting angles using screws or rivets. A minimum of 2 fasteners per mounting angle is required for rectangular dampers. A minimum of one fastener is required for round dampers.
3. On the sides adjacent to the retaining angles, a 3" long mounting angles is required. A minimum of two fasteners is required to attach the mounting angles to the damper. The bottom leg of mounting angle should rest on the ceiling material. Assure that the fasteners used to attach the mounting angles to the damper do not interfere with the damper blade operation.

REPRESENTED BY

MANUFACTURED BY
PERFECT AIR CONTROL, INC.

1310 N. HERCULES AVE. CLEARWATER, FL 33765
CUSTOMER SERVICE (800) 437-6653 * ORDER ENTRY FAX (727) 431-6074
www.prefco-hvac.com