

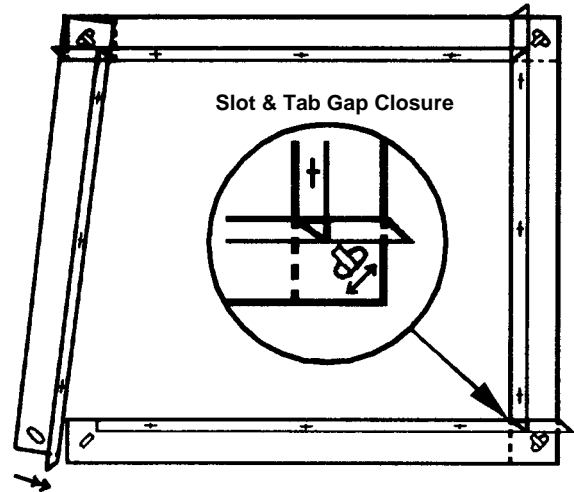

Rated per UL555, UL File R6189

Supplemental Installation Instructions For EZ Mount Retaining Angles For Use On 5000,5500 & 5600F Series Dampers Max Size 96" x 48"

The retaining angle may be used in lieu of conventional retaining angles on all fire & leakage rated dampers. See also sheet #5500II-4.

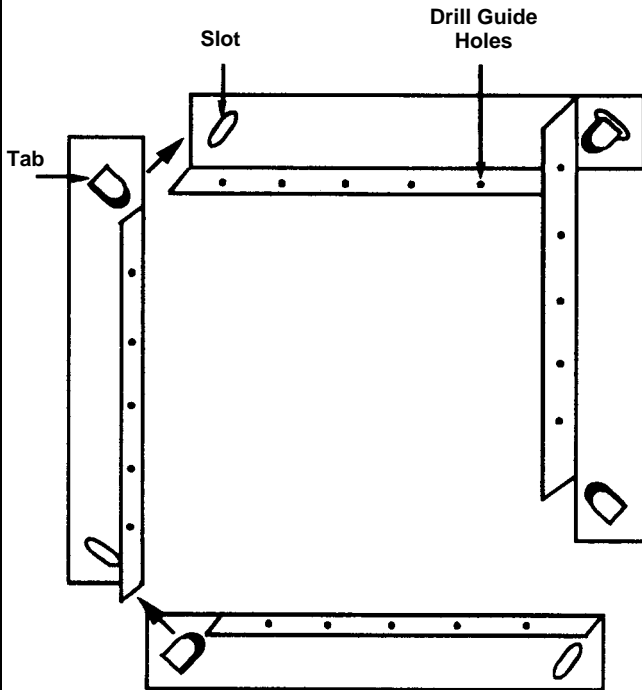

NOTES:

1. The retaining angle assembly for each side of partition has four parts, each with a tab end and a slot end. The tabs are to be inserted into the slots and knocked down either before or after fastening to the sleeve. The slots allow adjustment to meet field sleeve conditions. The angles are 1 1/2" x 1 1/2" x 16 Ga. steel.
2. Using the pre-punched holes, secure the angles to the sleeve with #14 sheet metal screws or 3/16" steel rivets. The angles are to overlap the wall or floor opening by 1" minimum and are not to be fastened to the wall or floor (See Single Side Angle Instructions for exceptions). Maximum clearance between wall and retainer is 1/2" per side.
3. Refer to appropriate damper installation instructions for complete installation data.
4. Pre-punched holes are provided in mounting angles for convenience. Not all holes will be required for fasteners. Refer to 5500II-4 for special requirements.

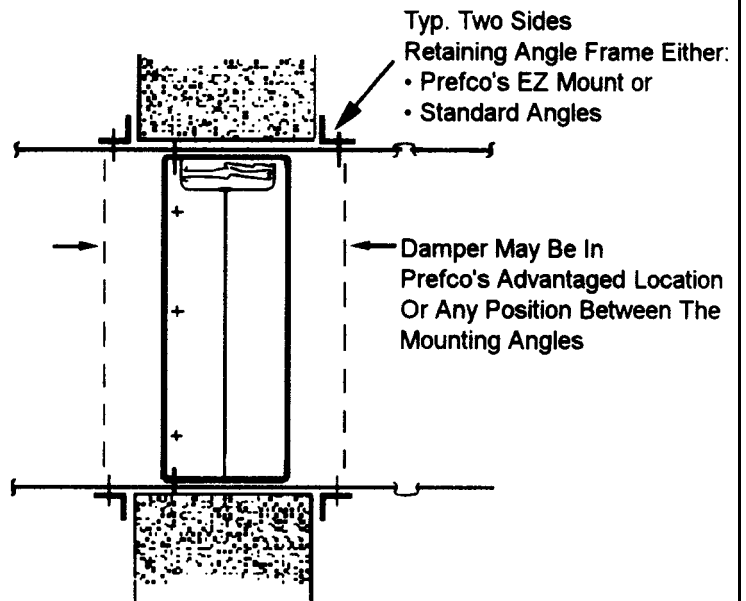

REPRESENTED BY

MANUFACTURED BY
PERFECT AIR CONTROL, INC.
 1310 N. HERCULES AVE. CLEARWATER, FL 33765
 CUSTOMER SERVICE (800) 437-6653 * ORDER ENTRY FAX (727) 431-6074
www.prefco-hvac.com