



Installation Instructions For Model 5630F Vertical Fire Dampers For Use In Static Systems

These Instructions Typify Both Horizontal And Vertical Installations Except As Noted,
And Apply Also To Masonry And Drywall Construction (see also Sheet GENII-2)

Rated per UL555, UL File R6189

NOTES:

1. Clearance between the wall/floor opening and the damper/sleeve assembly shall be 1/8" per foot of diameter. Minimum clearance shall be 1/4" for any size damper/sleeve assembly. Mounting angles shall overlap opening by 1" minimum on all sides.
2. The damper frame may be fastened to the sleeve using any of the following: 3/16" steel rivets, #14 sheet metal screws, #8 bolts and nuts or 1/2" tack welds spaced at a maximum of 8" center to center for 1-1/2 hour rated dampers. A minimum of two fasteners must be used.
3. Mounting angle rings must be installed on both sides of the wall/floor opening and rotated to prohibit a through opening between the mounting angle rings. Minimum mounting angle ring size is 1"x1"x18 gauge. Mounting angles are to be attached to the damper/sleeve assembly using any of the following: 3/16" steel rivets, #14 sheet metal screws, #8 bolts and nuts or 1/2" tack welds spaced at a maximum of 8" center to center for 1-1/2 Hour rated dampers. A minimum of two fasteners must be used. Fasteners must not interfere with blade operation.
4. As per UL555, for rigid joints the thickness of the sleeve shall be a minimum 18 gauge. EXCEPTION (to note #4): This requirement does not apply when one or more UL approved breakaway joints are used as the connection between the sleeve and ducts. In this case, the sleeve thickness shall not be less than that required by the Standard for the Installation of Air-Conditioning and Ventilating Systems, NFPA 90A.
5. When Model 5630F is used in duct outlet application, fabricate the sleeve as shown. Fasten the damper frame to the sleeve as in Note #2 above or Note #6 below. Install mounting angles as per Note #3 above. The sleeve may be flanged on one side in lieu of one mounting angle if the sleeve is a minimum of 16 gauge and the flange overlaps the wall opening by 1" minimum.
6. A single row of fasteners (per Note #3) may be used to attach the damper, sleeve and the mounting angles.
7. The plane of the blades when in the closed position must be within the wall/floor opening.
8. The model 5630F may be mounted with the blade axis in any position.

Instructions for Installations WITH Sleeves

No additional sleeve is required when the damper is installed in duct of 20 gauge or less and a UL approved breakaway connection is used.

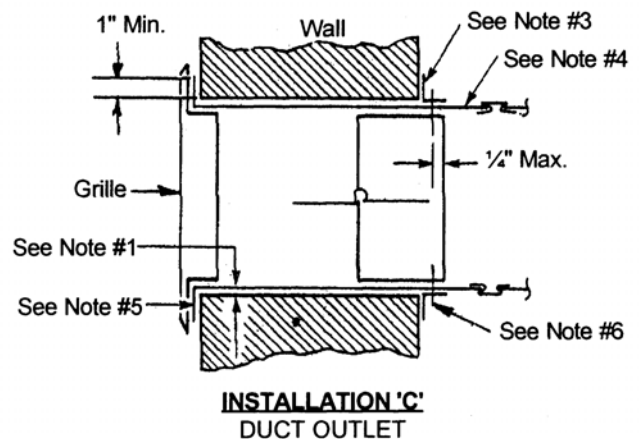
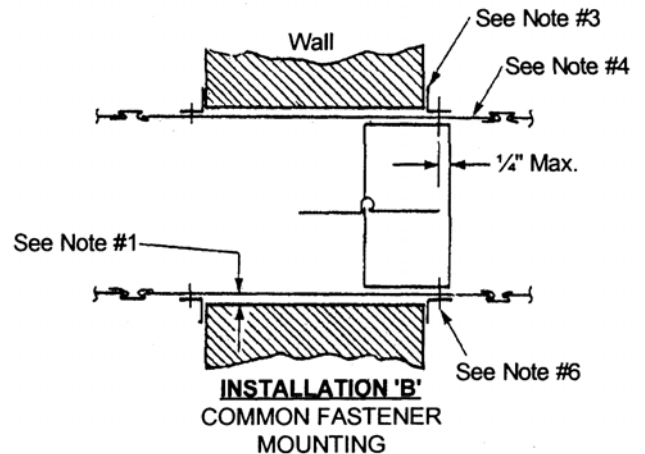
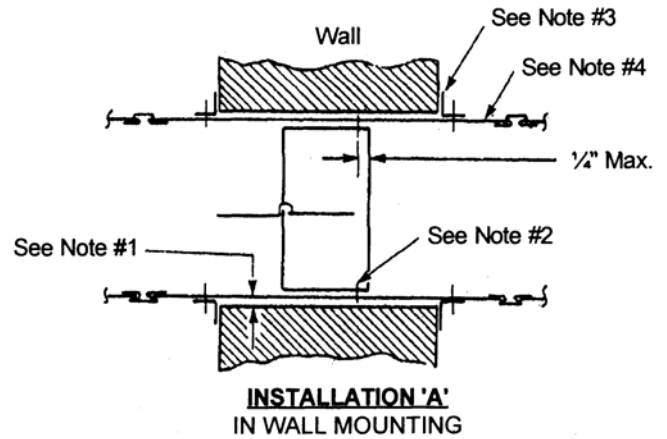

REPRESENTED BY

MANUFACTURED BY
PERFECT AIR CONTROL, INC.
1310 N. HERCULES AVE. CLEARWATER, FL 33765
CUSTOMER SERVICE (800) 437-6653 * ORDER ENTRY FAX (727) 431-6074
www.prefco-hvac.com